

Professional Engineers Registration Examination

PRACTICE *of* Professional Engineering Examination 2012

Information for Applicants



professional engineers board Singapore
5 Maxwell Road 1st storey Tower Block MND Complex Singapore 069110

Professional Engineers Registration Examination Practice of Professional Engineering Examination 2012 Information for Applicants

Contents	Page
1 Introduction	2
2 Description of Examination	2
3 Eligibility To Sit For Examination.....	2
4 Fees	3
5 Date of Examination.....	3
6 Venue	3
7 Application	3
8 Structure of Examination	3
9 Passing Requirements Final Results and Notification	4
10 Examination Appeals.....	4
11 Review Courses	4
12 Refund Of Fees	4

Annex A: FORMAT, SYLLABUS AND SAMPLE QUESTIONS

I Practice of Professional Engineering Examination - Part 1 (Common).....	5
II Practice of Professional Engineering Examination - Part 2 (Civil)	8
III Practice of Professional Engineering Examination - Part 2 (Electrical)	19
IV Practice of Professional Engineering Examination - Part 2 (Mechanical).....	30

Professional Engineers Registration Examination

Practice of Professional Engineering Examination 2012

Information for Applicants

1 INTRODUCTION

The mission of the Professional Engineers Board is to safeguard life, property, and welfare of the public by setting and maintaining high standards for registering professional engineers and by regulating and advancing the practice of professional engineering.

The Professional Engineers Board registers professional engineers in the branches of civil, electrical and mechanical engineering. A person applying for registration as a professional engineer to the Professional Engineers Board is required to hold an approved degree or qualification listed in the [Professional Engineers \(Approved Qualifications\) Notification](#) and acquired not less than 4 years of relevant practical experience. He is also required to sit and pass examinations prescribed by the Board. The applicant is required to sit and pass the Fundamentals of Engineering Examination and following that, to sit and pass the Practice of Professional Engineering Examination. In addition, the applicant is required to attend an interview.

The following sections set out the requirements and details for the Practice of Professional Engineering Examination 2012 while details on other application requirements are available on the PEB website at www.peb.gov.sg.

2 DESCRIPTION OF EXAMINATION

The Practice of Professional Engineering Examination tests the applicant's ability to apply his knowledge and experience in professional engineering practice, and his knowledge of the rules and regulations regulating the practice of professional engineering in civil, electrical or mechanical engineering.

3 ELIGIBILITY TO SIT FOR EXAMINATION

A person may apply to sit for the Practice of Professional Engineering Examination after he has-

- (a) completed 4 years of practical experience relevant to the branch of engineering that he seeks to be registered in; and
- (b) sat for and passed the Fundamentals of Engineering Examination.

4 FEES

The fee for an application to sit for the Practice of Professional Engineering Examination is \$450.

5 DATE OF EXAMINATION

The Practice of Professional of Engineering Examination 2012 shall be held on 9 May 2012.

6 VENUE

The venue would be determined by PEB and successful applicants would be informed of the details of the venue.

7 APPLICATION

Application and payment shall be submitted online at PEB's website. All applications are to be submitted to PEB with applicable fees and documents by 7 Mar 2012. Applicants are advised to send in their applications early to allow time for processing. They would be informed of the status of their applications and other details by post at least two weeks before the examinations.

8 STRUCTURE OF EXAMINATION

A summary of the structure of the Practice of Professional Engineering Examination 2012 is shown in the table below. The examination is 'open book' and further details are given in [Annex A: Format, Syllabus and Sample Questions](#).

Subjects	Time Allocated	Format
<u>PPE Part 1</u> Common paper	2 hrs 10 mins (9.00 am – 11.10 am)	<ul style="list-style-type: none"> • Answer 10 compulsory Multiple Choice Questions • Answer 3 out of 5 essay questions
<u>PPE Part 2</u> Civil/mechanical/electrical engineering	4 hrs 10 mins (1.00 pm – 5.10 pm)	<ul style="list-style-type: none"> • Answer 1 compulsory question plus 4 out of 6 questions (civil, electrical) • Answer 1 compulsory question plus 4 out of 7 questions (mechanical)

9 PASSING REQUIREMENTS, FINAL RESULTS AND NOTIFICATION

- (a) A candidate is required to take both Parts 1 and 2 when he sits for the examination unless he qualifies for an exemption as described in (b) below. Examination results will be given to candidates on a Pass/Fail basis and no scores or marks will be given to candidates. To obtain a 'Pass' in the examination, a candidate is required to obtain a pass score in both Parts 1 and 2 respectively.
- (b) A candidate who has taken both parts when he sits for the examination and obtains a pass score in only one of the two parts is deemed to have failed the examination. However, if he sits for the examination again, he would be granted an exemption from the part for which he has obtained a pass score. This exemption shall be granted provided the candidate sits for the examination again within a 3-year period from the date of result. With the exemption, he would only need to take the part of the examination for which he did not obtain a pass score. No exemption shall be granted if he sits for the examination again after the exemption period, in which case he is required to take both Parts 1 and 2.
- (c) Examination results will be mailed to the candidates within twelve weeks after the examination.

10 EXAMINATION APPEALS

A candidate who has failed the examination may submit a written appeal to review his/her performance together with a payment of \$25. The appeal is to be made within 2 weeks after the receipt of results and late appeals would not be considered. The result of the appeal/review will be sent by written mail to the appeal candidate. The appeal candidate would not be able to review his examination paper.

11 REVIEW COURSES

The Board does not endorse any review course or material provided as study aids.

12 REFUND OF FEES

Where an applicant who has been accepted is unable to sit for the examination subsequently, the Board may, at its discretion, refund \$150 to the applicant if the applicant informs the Board at least a week before the examination or submit a medical certificate within 2 weeks after the examination. There will be no refund if the applicant informs the Board less than a week before the examination.

Annex A: FORMAT, SYLLABUS AND SAMPLE QUESTIONS

I Practice of Professional Engineering Examination Part 1 (Common)

Professional conduct and ethics are important areas because most of the disciplinary actions taken by the Professional Engineers Board are in the area of ethics and not technical matters. Professionalism and ethics are closely related and inseparably bound as professional status and recognition are based on public interest. A professional engineer's judgment and decisions can have great impact on public health and safety. He is expected to uphold the dignity, standing and reputation of the profession. He shall practise ethically in relation to his clients, employers, fellow professionals and the public at large.

Format

This is a common paper which has two sections on the Professional Engineers Act and Professional Conduct and Ethics. The paper comprises 10 multiple choice questions (MCQs) and 5 essay type questions based on hypothetical case studies. The candidates must answer all the 10 compulsory MCQs (25 marks) and can choose to answer any 3 out of the 5 essay questions (75 marks) during the 2 hrs 10 mins examination period.

Syllabus

The paper will focus on the latest revisions of the following Professional Engineers Act and Rules:

- Professional Engineers Act
- Professional Engineers (Code of Professional Conduct and Ethics) Rules
- Professional Engineers Rules

References will also be made to past disciplinary actions taken by the Professional Engineers Board arising from complaints against professional engineers.

Questions will be set to test the candidates' understanding and interpretation of the provisions in the act and rules as well as how they will tackle hypothetical cases involving the clients, the employers, fellow professionals and the public at large.

Sample Questions From Past Year Papers for Practice of Professional Engineering Examination Part 1 (Common)**Section A - Answer 10 Compulsory Multiple Choice Questions**

(Total : 25 marks)

- 1 Under what circumstances shall a professional engineer advise the client to engage the services of experts and specialists?
 - (a) The professional engineer shall give the advice when in his opinion and judgment such services are in the interest of his client.
 - (b) The professional engineer shall give the advice when he feels such services will pass the responsibility to others.
 - (c) The professional engineer shall give the advice when he can indirectly benefit from the appointment of experts and specialists.
 - (d) The professional engineer shall give the advice when he considers that in doing so the cost input of his company will be reduced.

- 2 A professional engineer may publicise his practice. However, in doing so, the professional engineer shall ensure that the publicity —
 - (a) contains information that is related to all the projects undertaken by him or his company but without the consent of the clients.
 - (b) contains only information beneficial to his business even though it is likely to diminish public confidence in the engineering profession or to otherwise bring the profession into disrepute.
 - (c) contains only justifiable claims to expertise or specialization; makes no reference to past project information which constitutes a breach of confidentiality to the client; and does not compare or criticise the quality of services provided by any other professional engineer or allied professional.
 - (d) contains information with material facts even if it may create an unjustified expectation about the results that can be achieved by him.

- 3 Engineer A provides design, plans and specifications for a commercial building to Developer P who submits them to the authority for approval but fails to pay Engineer A for the work performed. Thereafter, Developer P asks Engineer B to review, endorse and resubmit the plans to the authority for approval. Shall Engineer B agree to undertake the project?
 - (a) Engineer B shall not agree to undertake the project as he has an ethical obligation to recognise and give credit to the creative works of other engineers.

-
- (b) Engineer B shall agree to undertake the project as long as Engineer A does not complain.
 - (c) Engineer B shall agree to undertake the project as Engineer A does not know.
 - (d) Engineer B shall agree to undertake the project as he is employed by the Developer.

Section B - Answer 3 Out Of 5 Essay Questions

Question 1

Engineer A, on behalf of the engineering firm of which he is a principal, submitted a statement of qualifications to a developer for a mega project.

In due course he was notified that his firm was on the "short list" for consideration along with several other firms, but it was indicated to him that his firm did not appear to have qualifications in some specialised aspects of the requirements, and that it might be advisable for the firm to consider a joint venture with another firm with such capabilities.

Engineer A thereupon contacted Engineer B, a principal of a firm with the background required for the specialised requirements, and inquired if Engineer B's firm would be interested in a joint venture if Engineer A was awarded the job. Engineer B's firm responded in the affirmative.

Thereafter, Engineer C, a principal in a firm which was also on the "short list," contacted Engineer B and indicated the same requirement for a joint venture for specialised services, and also asked if B's firm would be willing to engage in a joint venture if the C's firm was selected for the assignment. Engineer B also responded in the affirmative to Engineer C but did not notify Engineer A of his response to Engineer C.

Is it ethical for Engineer B to agree to participate in a joint venture arrangement with more than one of the several since he did not make a full disclosure to all of the firms?

Discuss the issues and comment on Engineer B's conduct with reference to relevant sections of the Professional Conduct and Ethics rules where applicable.

(25 marks)

II Practice of Professional Engineering Examination Part 2 (Civil)

The paper aims to examine the candidates on their proficiency in the practice of civil/structural engineering at a professional level. Candidates are expected to have a good working knowledge and experience of civil/structural engineering design and practices in Singapore. In particular knowledge is required in the areas of regulatory framework, submission and approval procedures, statutory acts and regulations, practices guidelines and codes of practice.

The examination will place emphasis on the Professional Engineer's role in building projects in the local context either acting as the Qualified Person for the project or Professional Engineer for the civil and structural engineering works.

Format

This is a 4 hrs 10 mins paper and a candidate is required to answer 1 compulsory question covering the design of concrete and steel structures and choose 4 out of 6 questions covering areas of design, codes of practice, acts and regulations, submission/approval procedures & site supervision. The candidates may bring along their own reference materials and calculators as necessary.

Syllabus

The list of reference literature, codes, acts, regulations, etc appended below is meant as a guide and is not exhaustive.

- **Acts and Regulations**
 - Professional Engineers Act and Regulations
 - Building Control Act and Regulations
- **Publications**
 - **URA**
 - Planning Control Handbooks and Guidelines for Building Works
 - **SCDF**
 - Code of Practice for Fire Precautions in Buildings
 - Handbook on Fire Precautions in Buildings
 - FSSD Fire Safety Handbooks

- **LTA**
 - Guidelines & Publications on Rapid Transit Systems
 - Building Works & Restricted Activities in Railway Protection Zone
 - Street Proposals
 - Vehicle Parking
 - Other Guidelines and Standards

- **NEA**
 - Code of Practice on Environmental Health
 - Code of Practice on Pollution Control

- **PUB**
 - Code of Practice on Surface Water Drainage
 - Standard Specifications for Drainage Works
 - Code of Practice on Sewerage and Sanitary Works
 - Sewerage and Drainage Standard Drawings

- **NParks**
 - Procedures and Guidelines for Plan Submissions

- **MOM**
 - Workplace Safety & Health Act and Subsidiary Legislations

- **BCA**
 - National Productivity and Quality Specification (NPOS)
 - Guidelines and Handbooks on Civil Defence Shelters
 - Code of Practice on Buildable Design

- **Civil Engineering Codes/Standards**
 - Codes and Standards under Building Control Act and Regulations
 - Codes and Standards for Roads and Transit Systems to LTA's Requirements

Sample Questions From Past Year Papers for Practice of Professional Engineering Examination Part 2 (Civil)

Section 1- Question 1 is COMPULSORY

Section 1

Question 1

You are engaged by the owner for addition and alteration works to an existing 2-storey conservation building. The owner requires a column free layout at the 2nd storey in order to utilize the whole space as a training center. (Fig 1.1 and Fig 1.2)

- (a) Fig 1.3 shows the existing beam (300 mm × 400 mm) which has been strengthened with 2 Nos of 533 × 210 × 101 U-beams. Perform a detailed check of the proposed 533 × 210 × 101 U-beams to verify that the steel sections provided are structurally adequate.

Design Data:

Material:	S355 structural steel
Roof dead load:	2 kN/m ²
Live load:	0.75 kN/m ²
Ceiling:	0.50 kN/m ²

Assumptions:

Ignore any contribution in strength from the existing concrete beam.
The beam is not laterally braced along its 11m length. (25 marks)

- (b) The above mentioned strengthened beam rests on a 200 × 200 mm RC column. Fig 1.4 shows that an assumed vertical factored load of 103.8 kN is transferred to a footing with an additional applied moment of 20 kNm. Calculate the shear stress at the critical section and design the footing reinforcement and neatly sketch a cross-section of the footing showing the position of the reinforcement.

Design data:

Footing concrete:	35 N/mm ²
Concrete cover:	50 mm
Rebar strength:	460 N/mm ²

(25 marks)

Question 1 (Continued)

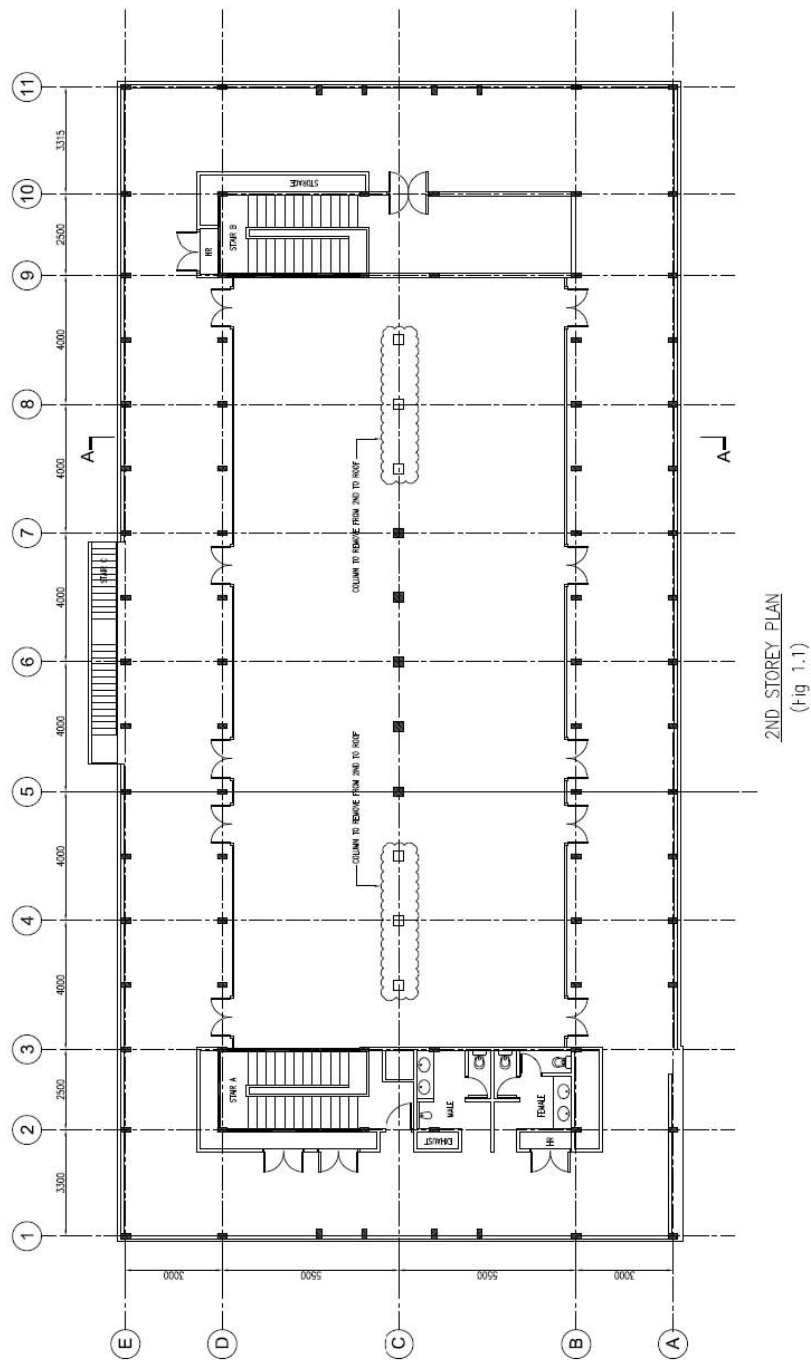

Question 1 (Continued)

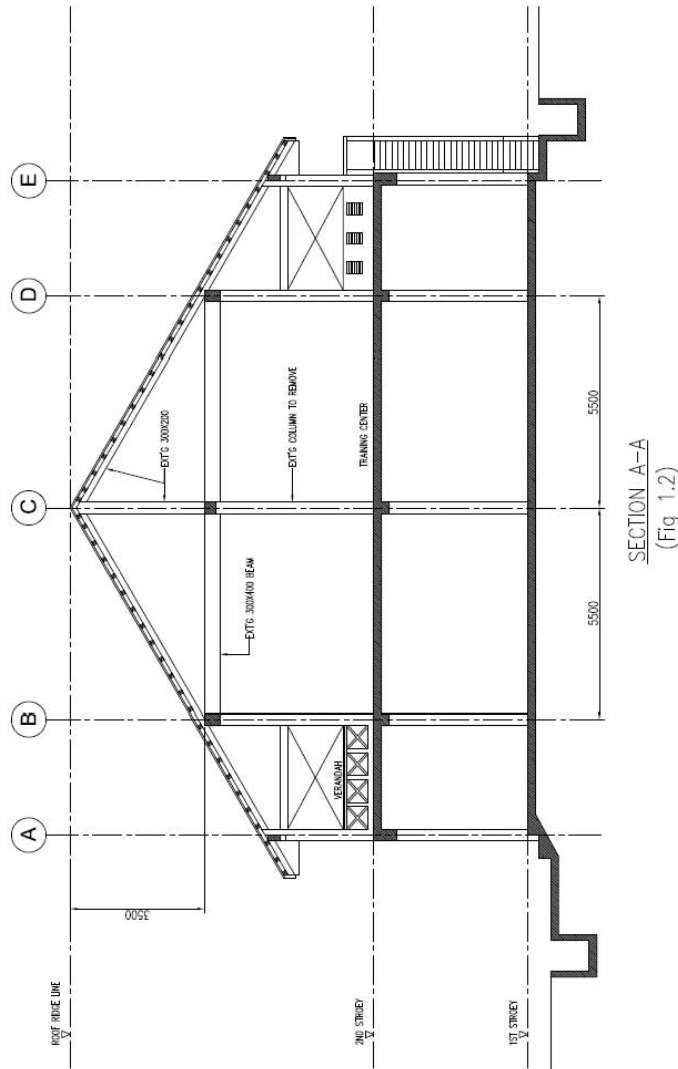

Question 1 (Continued)

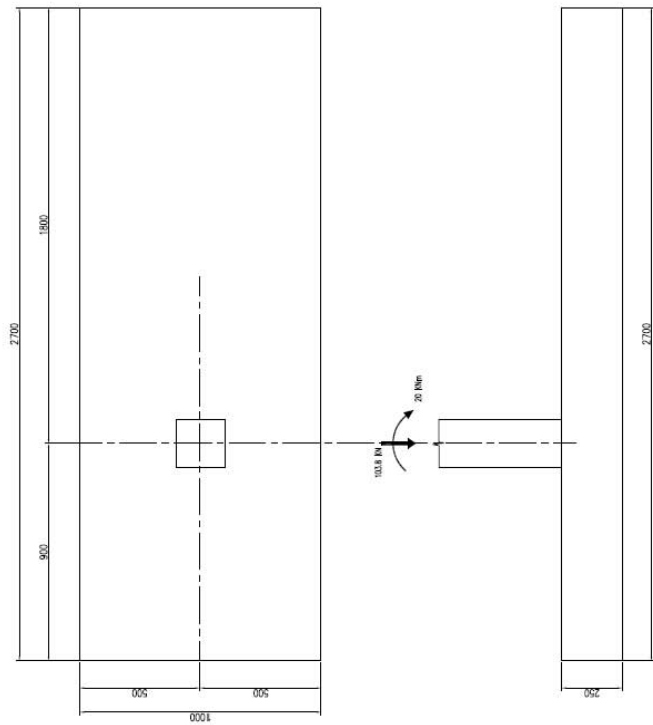

(Fig 1.4)

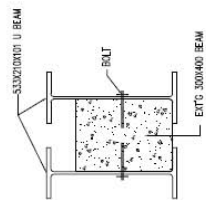

(Fig 1.3)

Section 2 - Answer 4 Out Of 6 Questions

Question 5

A new 10-storey commercial development is located in a built up area of Singapore. The proposed grid is 8m x 8m. One side of the site boundary is 6m from the MRT 1st Reserve Line. Crown level of the existing 6m diameter MRT Tunnel is at RL 85. There is a set back requirement of 5m from the boundary. Platform Level is RL 100. The soil investigation report is provided by URA during land sale (Fig 5-1).

- (a) Propose the foundation type, justify with preliminary calculations and give reasons for your recommendation. (5.5 Marks)
- (b) State the consideration for Rail Way Protection Requirement and illustrate with diagrams. (3 Marks)
- (c) List the structural submission requirements of BCA and LTA. (4 Marks)

Question 5 (Continued)

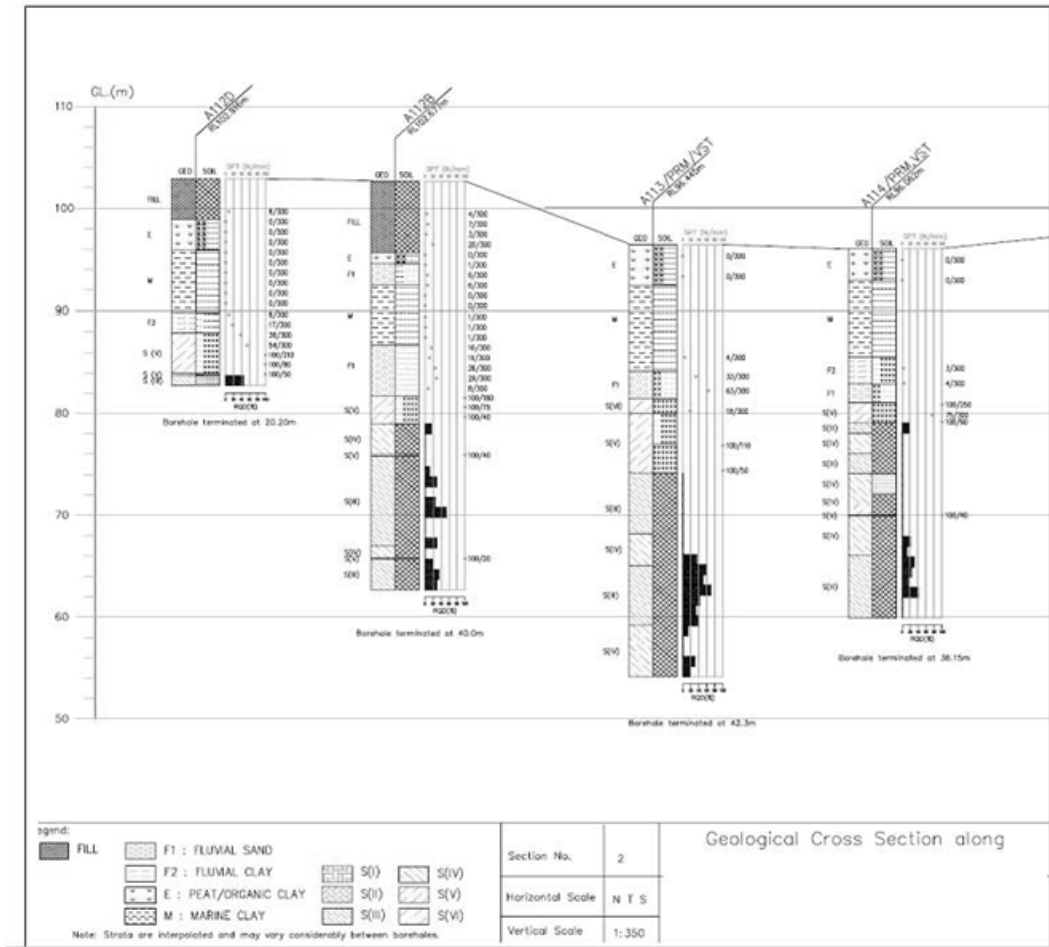

Fig 5-1

Question 6

(References are provided in Annex 2 at page 35)

- (a) You are appointed as Qualified Person for an A&A project of a bungalow house. The owner would like you to provide a basement at RL 111.50. You are required to propose a feasible sewer system for the discharge of toilet waste from the basement to the existing manhole located on the road outside. Draw the proposed new sewer line layout clearly on a plan (Fig 6-1). (Answer sheet is provided for use. You should attach it to your answer booklets). Your answer shall include the proposed minimum new top level and the invert level of the new manholes. Explain your proposed layout.

(6 Marks)

- (b) At the back of the bungalow is a plot of state land. The owner wanted to buy over that piece of state land and use it to accommodate part of his basement with the same platform level (at RL 111.50) with the extension open to the sky. As a QP, you found out that there is a problem in discharging the rain water to the existing open channel drain located at the back of the state land after consulting the Drainage Department. Elaborate on what would be possible problems associated with the current layout plan.

(3 Marks)

- (c) In view of the Authority's comments above, a pump drainage system is required for discharging the rain water at the basement level. Given that the total basement area exposed to the open air is 200m². As the QP, provide the minimum required size of pump sump.

(3.5 Marks)

Question 6 (Continued)

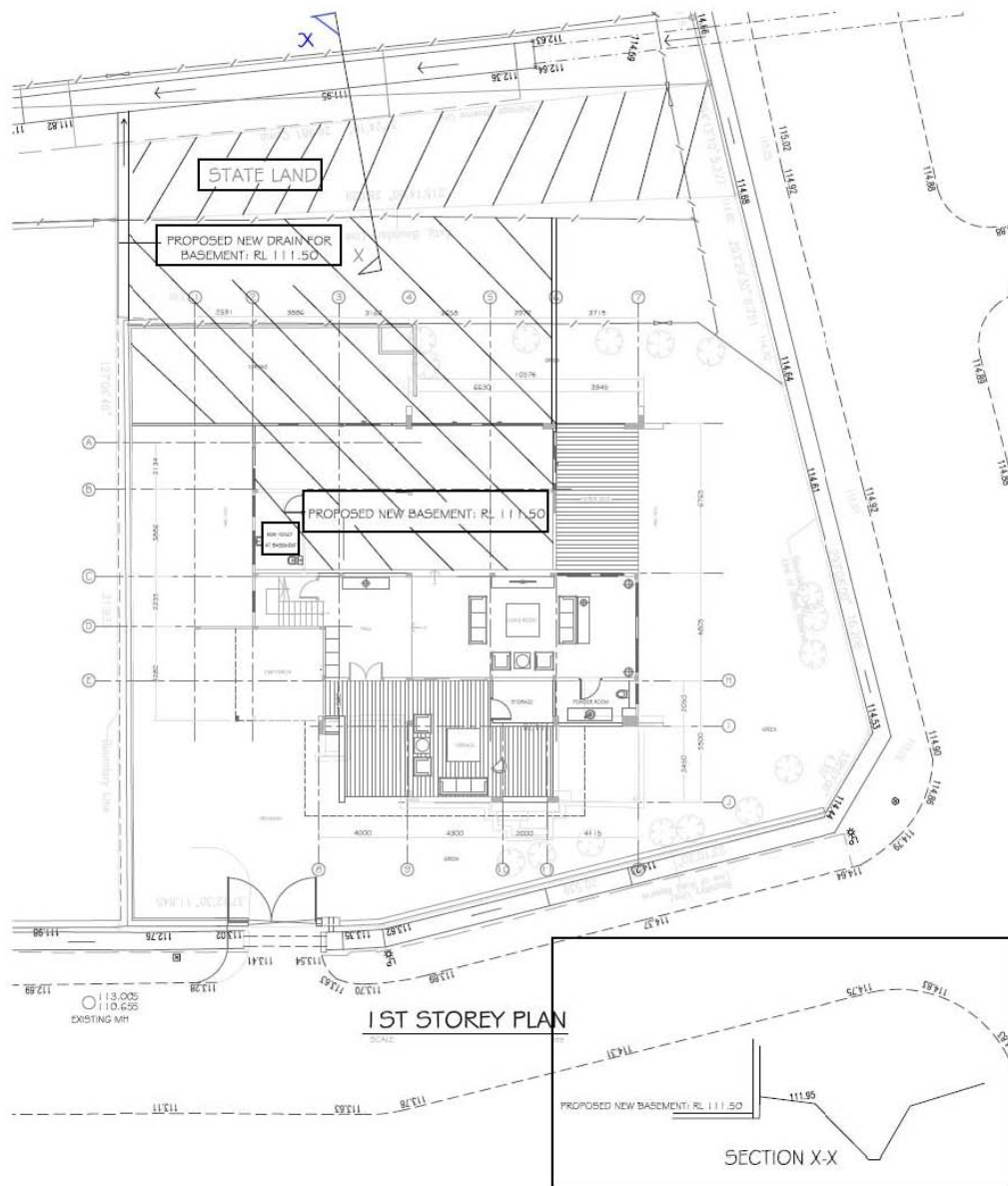

Fig 6-1

III Practice of Professional Engineering Examination Part 2 (Electrical)

The paper aims to examine the candidates on their proficiency in the practice of electrical engineering at a professional level. Candidates are expected to have a good working knowledge and experience of electrical engineering design and practices in Singapore. In particular knowledge is required in the areas of regulatory framework, submission and approval procedures, statutory acts and regulations, practices guidelines and codes of practice.

The examination will place emphasis on the Professional Engineer's role in building projects in the local context in relation to electrical engineering works.

Format

This is a 4 hrs 10 mins paper that examines candidates on technical competency and understanding of standards and codes that are applicable in Singapore for the discipline of electrical engineering.

The paper consists of 2 Sections and 7 questions. Candidates must answer questions in both sections (Section 1 and Section 2). Section 1 consists of a compulsory question on CP5 and statutory acts and regulations. Candidate is required to answer this compulsory question. Section 2 consists of 6 questions. Candidates shall choose to answer 4 out of 6 questions.

Syllabus

- **Codes of Practice**
 - CP 5: Code of Practice for Electrical Installations
 - CP 10: Installation and Servicing of Electrical Fire Alarm System
 - CP 15: Installation, Operation and Maintenance of Escalators
 - CP 39: Installation of MATV for the reception of VHF and UHF Sound and TV
 - CP 88: Temporary Electrical installations for construction and building
 - SS 209: Battery operated emergency power supply for lighting, ventilation and alarm bell of lifts
 - SS 530: Code of practice for energy efficiency standard for building services and equipment.

-
- SS531-1: Code of practice for lighting of work places – Indoor.
 - SS531-2: Code of practice for lighting of work places – Outdoor.
 - SS531-3: Code of practice for lighting of work places - Lighting requirements for safety and security of outdoor work places.
 - SS532: Code of Practice for the Storage of Flammable Liquids.
 - SS535: Installation, Operation, Maintenance, Performance and Constructional Requirements of Mains Failure and Standby Generating System.
 - SS538: Code of practice for maintenance of electrical equipment of electrical installations.
 - SS546: Emergency voice communication system in building.
 - SS 550: Installation, Operation and Maintenance of Electric Passengers and Goods Lifts.
 - SS551: Code of Practice for Earthing.
 - SS555: Code of practice for protection against lightning.
 - SS558: Code of practice for construction, installation, operation and maintenance of intruder alarm systems.
 - SS 563-1: Code of practice for the design, installation and maintenance of emergency lighting and power supply systems in buildings. Part 1 : Emergency lighting.
 - SS 563-2: Code of practice for the design, installation and maintenance of emergency lighting and power supply systems in buildings. Part 2 : Installation requirements and maintenance procedures.
 - Handbook for Application of Installation Licence published by EMA
 - Fire Code 2007
 - Reference document of Singapore Green Building Council (SGBC) available at SGBC website under Publications: <http://www.sgbc.sg/index.php/green/publications/>
 - CP on Environmental Health

- **Electrical Power Supplies, Tariffs and Design**
 - Electricity market
 - Generation, transmission and distribution in Singapore
 - Handbook on Application for Electricity
 - Handbook on Solar Photovoltaic (PV) Systems
 - Electricity bill calculation for HT and LT consumers
 - Design of electrical installations
 - Load estimation
 - Power factor correction
 - Power quality and power system harmonics
 - Consumer Substation, Switchboards and Switchgears
 - Maintenance of electrical equipment, switchgears and cables
 - Design for energy efficiency and sustainability

- **Lighting requirement for workplace, indoor and outdoor**
 - Visual needs for safety and security
 - Determine the lighting requirements for indoor and outdoor work places.

- **Energy efficiency requirement**
 - Minimum energy-efficiency requirements for new installation and replacement of systems and equipment in buildings
 - Replacement of components of systems and equipment in buildings
 - Criteria for determining compliance with energy efficiency in building with regards to air-conditioning and heat rejection equipment, water heaters, motor drives and lighting used in buildings.

- **Protection for Safety**
 - Measures in protection against electric shock (direct and indirect)
 - Principle of operation of protective devices
 - Maximum demand and diversity factors
 - Protection against over-current and short circuits
 - Protective devices and circuit conductors
 - Discrimination in protection of electrical circuits
- **Cables, Busways and Distribution Boards**
 - Type and characteristic of cables
 - Method of installation
 - Sizing of conduit and trunking
 - Factors affecting the current carrying capacity of cables
 - Sizing of cables and busways for use under different types of conditions
 - Connected load, maximum demands and circuit breakers ratings for a electrical distribution board
- **Earthing**
 - Purpose of earthing
 - Methods of earthing
 - Earth fault loop impedance and earth fault current
 - Suitable sizes of circuit protective conductor
 - Testing of earthing
- **Lightning Protection Systems**
 - Rolling sphere technique of determining zones of protection

- Spacing of air terminations and types of air termination
- Down conductors for building below 45 metres and those exceeding 45 metres
- Earth electrodes, earth resistance values and hazards of a rise in ground potential caused by lightning strike
- Selection of appropriate materials and installation methods
- Prevention of side flashing
- Design requirement of complete lightning protection system
- Transients and surge suppression
- Effect of lightning on system and structure
- Source and type of damages due to lightning
- Risk assessment aspect in lightning protection
- **Emergency Lighting**
 - Exit and emergency lighting requirements for evacuation of occupants
 - Types of back-up power supplies
 - Exit and directional Signs
- **Standby Power Generator System**
 - Types of essential and critical loads
 - Sizing of generator with considerations for maximum demand of essential load, transient or motor starting loads and voltage dip
 - Voltage regulation and its effects on generator sizing
 - Protection for alternator and prime mover
 - Installation of standby generator system including day-tank, battery and charger, fuel supply, engine cooling system, plant room ventilation, exhaust and fresh air intake, control and instrumentation panel and automatic transfer switch.

- Underground fuel storage system
- Grounding/Earthing arrangement
- Maintenance

- **Automatic Fire Alarm System**
 - Requirement for automatic and manual fire detection system and purpose of compartmentation as required by the Fire Code
 - Interaction with other building services such as emergency voice communication system, lifts, AHUs, pressurization fans and auto-doors during alarm activation

- **Emergency Voice Communication System**
 - Requirements for public address system for building above 24 metres but less than 60 metres
 - Requirements for emergency voice communication for building above 60 metres
 - Requirements for fireman intercom

- **Inspection, Testing and Common Violation In Electrical Installation**
 - Mandatory requirements for inspection and testing of electrical installation prior to energisation of electrical supply
 - Types of test instruments and standard methods of testing

Sample Questions From Past Year Papers for Practice of Professional Engineering Examination Part 2 (Electrical)

Section 1 - Question 1 (28 marks) is COMPULSORY

Q1.

- 1(a) Explain the difference and purpose of bonding and earthing as required for an electrical installation in Singapore.
You are checking the lightning protection system for a building for compliance to the new code, what is the minimum size of stranded copper bonding conductor allowed to connect the non-ferrous connector point to the earth termination system?
- 1(b) You are the LEW responsible for the electrical installation in a newly built mixed development. The main switchboard is ready for turn on. Identify the certificate(s) to be submitted to SP Services Ltd (SPPL) when you request for an energisation appointment.
- 1(c) An electrical installation with an approved load of 1000 KVA is taking direct supply from PowerGrid's network. The low voltage main switchboard (MSB) with air circuit breaker (ACB) had passed the factory acceptance test and was delivered to site; feeder cables were laid and terminated to the MSB. Identify the tests to be carried out on site before requesting for the turn-on by SP Services Ltd (SPPL).
- 1(d) Explain the purpose of the primary injection test.
- 1(e) Refer to the distribution board shown in Figure Q1(e). A new load, an air handling unit (AHU) rated at 11 kW 3-phase 400V at 0.8 pf, will be added to the distribution board.
- (i) Is there a need to upgrade the incoming breaker size and the bus bar ratings of the distribution board? State the reason(s) for your answer.
 - (ii) Determine the current rating of the MCB and the cable size for the new AHU. Assume that the cable length from the distribution board to the new AHU is 20m and the permitted Line-Line voltage drop is 8V.
 - (iii) Is there a change in the short-circuit rating of the MCCB in the distribution board when the new load is added? State the reasons for your answer.

- (iv) How would the LEW in-charge of the operation and maintenance of the electrical installation isolate the distribution board to make it safe for the modification works to be carried out? Elaborate on the procedures and safety measures to be taken before physical works on the distribution board can commence.

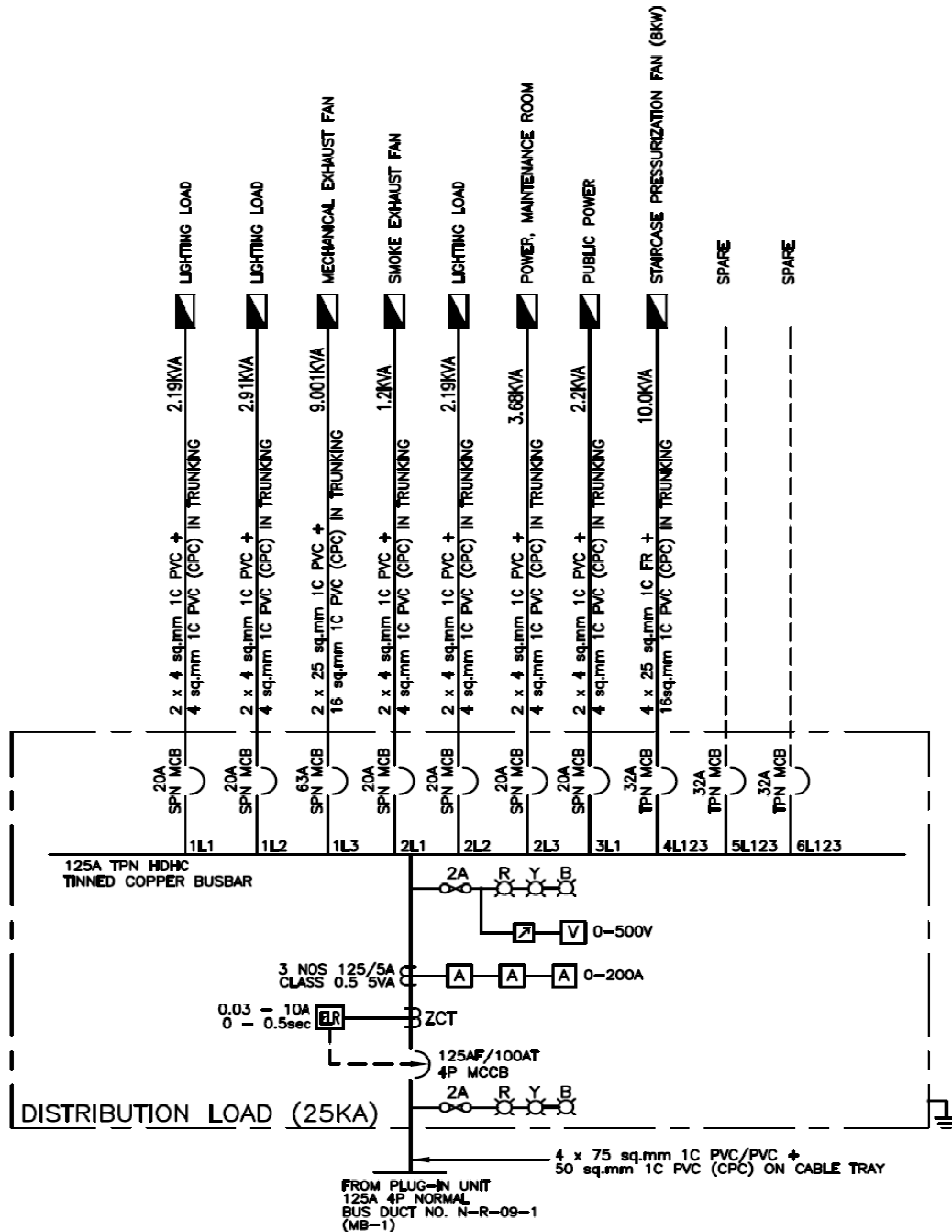

Figure Q1(e)

Section 2 – Answer 4 Out Of 6 Questions (each at 18 marks)

Q2.

- 2(a) There are four electromagnetic interference (EMI) coupling modes, shown by the four arrows A, B, C and D in Figure Q2(a). Identify the type of coupling modes for each arrow.

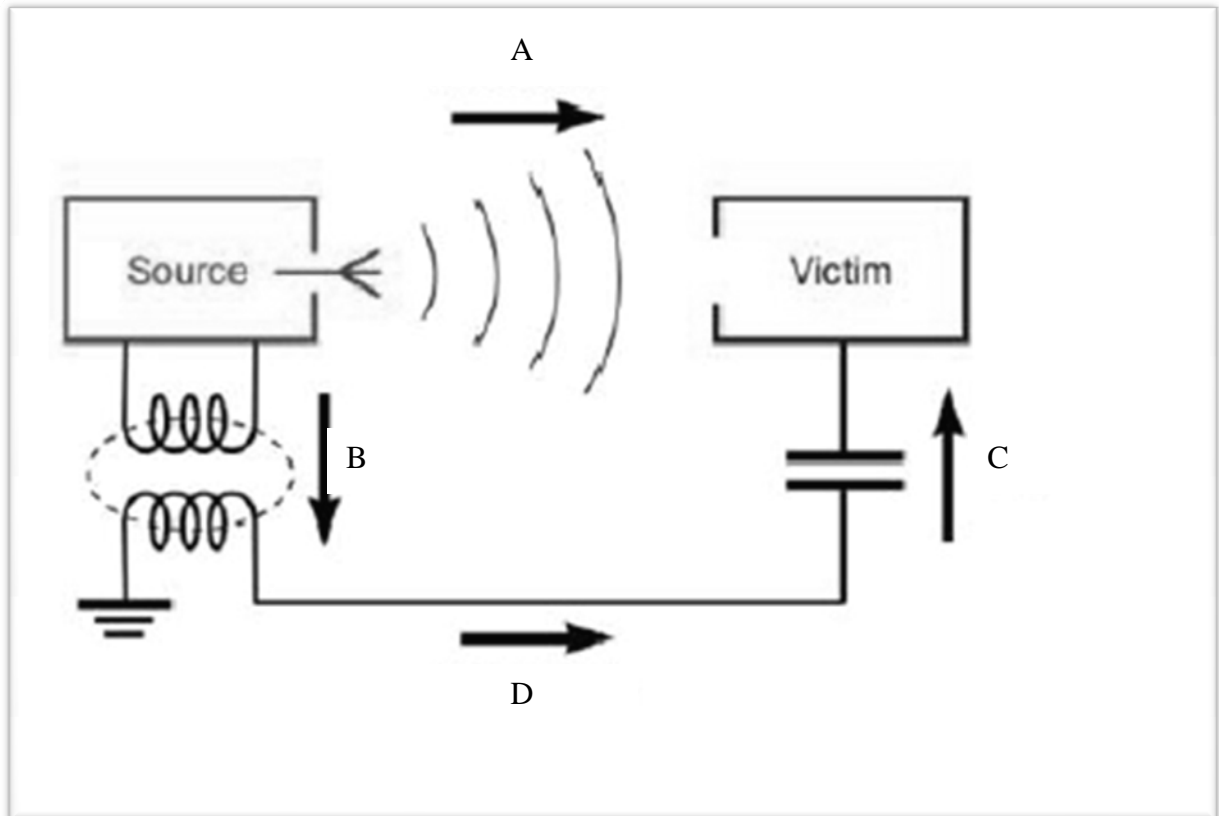

Figure Q2(a)

- 2(b) The cable arrangement in an electrical installation can be designed and installed to achieve a significant reduction in electric and magnetic field associated with the cabling system. List four (4) measures you would recommend to achieve the reduction.
- 2(c) You are to design, using the rolling sphere method, a lightning protection system to a group of buildings as shown in Figure Q2(c). Mark directly onto the Figure Q2(c) as to where the air termination system is to be installed and detach the page for submission together with your answer script. You are to draw circles, or part of it, to illustrate your answer.
- 2(d) What are the factors governing the radius of the rolling sphere? To comply with Building Control Regulation, what is the minimum level of lightning protection system to be adopted?

- 2(e) You are designing a lightning protection system for a school. There is an outdoor school field. What lightning protection systems/measures would you recommend? Give reasons for your recommendation.
- 2(f) Explain what you understand by the term "30/30" lightning rule.

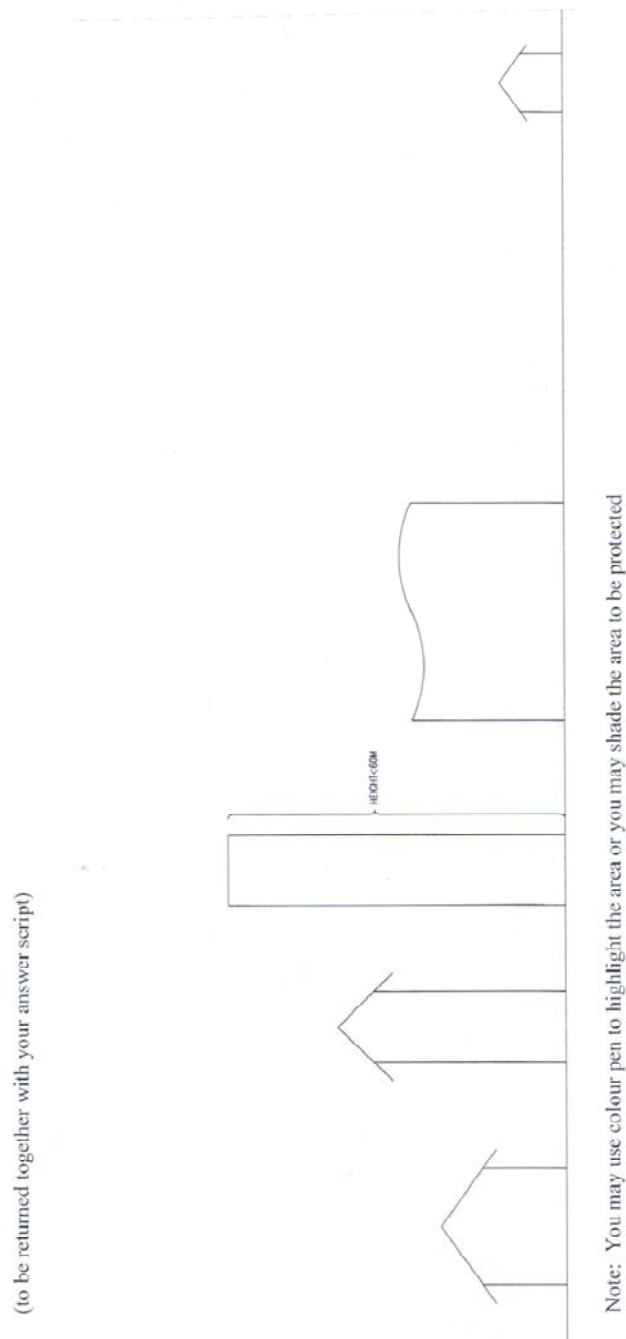

Figure Q2(c)

Q3.

- 3(a) Before work can commence on a high voltage switchboard, what are the 5 essential steps that need to be carried out to ensure the safety of the workers? Assume that you can only shut down half of the switchboard.
- 3(b) With the aid of a diagram, describe the protection requirements of the incoming panel of a 22 kV supply. You should include the type, rating and accuracy class of various devices where appropriate.
- 3(c) A 22kV/400V 2-MVA transformer is connected directly to the "incoming mains" air circuit breaker of a LV switchboard. The 22 kV cable is protected by an IDMTL overcurrent relay R1 which is connected to 100/5A current transformers. R1 is set at 50% plug setting and time multiplier at 0.3. The protection on the LV side is an IDMTL overcurrent relay R2 which is connected to 3000/5A current transformers. Both the relays R1 and R2 have the same time-current characteristic which is given by:

$$t = 0.14 / (M^{0.02} - 1) \text{ secs (for Time Multiplier = 1)}$$

where M = Plug Setting Multiplier

The symmetrical fault current at the 400-V switchboard is 36,000 A. Determine a suitable plug setting and a suitable time multiplier for relay R2 if the time discrimination between the two relays R1 and R2 is 0.4 secs.

Available plug settings for the two IDMTL relays are 50%, 75%, 100%, 125%, 150%, 175% and 200%.

Assume the LV circuit breaker does not have direct-acting element.

IV Practice of Professional Engineering Examination Part 2 (Mechanical)

The paper aims to examine the candidates on their proficiency in the practice of mechanical engineering at a professional level. Candidates are expected to have a good working knowledge and experience of mechanical engineering design and practices in Singapore. In particular knowledge is required in the areas of regulatory framework, submission and approval procedures, statutory acts and regulations, practices guidelines and codes of practice.

The examination will place emphasis on the Professional Engineer's role in building projects in the local context in relation to mechanical engineering works.

Format

This is a 4-hour paper that examines candidates on technical competency and understanding of the use and application of standards and codes that are applicable to the practice of mechanical engineering at a professional level in Singapore.

The paper consists of 2 Sections comprising a total of 8 questions. Candidates are required to answer questions in both sections (Section 1 and Section 2). Section 1 will consist of a compulsory question on principles, codes, and legislation related to general mechanical engineering practice, safety and environmental protection. Section 2 will consist of a total of 7 optional questions. Candidates may choose to answer any 4 out of the 7 questions.

Syllabus

The scope of professional engineering work covered by Professional Engineers (Mechanical) may include the following fields: -

- **Piped Services**

Cold and Hot Water Services; Sanitary Plumbing Systems within buildings; Town Gas Incoming Supply and Distribution; Liquefied Petroleum Gas (LPG) Multi-Cylinder Systems; Swimming Pool Filtration System

- **Air Conditioning & Mechanical Ventilation**

Indoor Air Quality Comfort / Environmental Control / Fire Safety Requirements

- **Fire Safety in Buildings**

Wet and Dry Rising mains/Hydrant Systems; Fire Hose reel System; Automatic Fire Sprinkler System; Fire Detection and Alarm System; Gas Flooding System

- **Lift and Hoisting Systems**

Lifting / Hoisting Equipment

- **Other Major Mechanical Systems and Services**

Boiler Plants, Calorifiers, Pressure Vessels, Pressure Piping

- **Energy Conservation for Mechanical Building Services / Buildings**

- **Relevant Codes of Practices, Standards and Acts**

All relevant regulations, by-laws, Acts and accepted codes of practice of:-

- National Environment Agency
- Public Utilities Board
- PowerGas Ltd
- PowerGrid Ltd
- Singapore Civil Defence Force
- Ministry of Manpower
- Building and Construction Authority
- Energy Market Authority

- **Singapore Standards – Codes of Practice**

- SS 550: Installation, Operation and Maintenance of Electric Passengers and Goods Lifts.
- CP 10 : Code of Practice for The Installation and Servicing of Electrical Fire Alarm Systems
- SS553: Code Of Practice For Air-Conditioning And Mechanical Ventilation In Buildings (Formerly CP13)

-
- CP 15: Code of Practice for Installation, Operation and Maintenance of Escalators and Passenger Conveyors
 - SS530 – Code of Practice for Energy Efficiency Standard for Building Services and Equipment
 - CP27: Code of Practice for Factory Layout – Safety, Health and Welfare Considerations
 - CP29: Code of Practice for Fire Hydrant Systems and Hose Reels
 - CP34: Code of Practice for bulk liquid oxygen storage installation on user premises
 - CP35: Code of Practice for the selection, care and maintenance of steel wire ropes for hoisting
 - CP37: Code of Practice for safe use of mobile cranes
 - SS532 – Code of Practice for the Storage of Flammable Liquids
 - CP48: Code of Practice for Water Services
 - CP51: Code of Practice for Manufactured Gas Pipe Installation
 - CP52: Code of Practice for Automatic Fire Sprinkler System
 - CP55: Code of Practice for Use and Maintenance of Portable Fire Extinguishers
 - CP62: Code of Practice for safe use of tower cranes
 - CP63: Code of Practice for the lifting of persons in work platforms suspended from cranes
 - NFPA 2001: Standard for Clean Agent Fire Extinguishing systems (FM200)
 - American Society of Mechanical Engineers codes on pressure vessels and piping
 - American Petroleum Institute codes on pressure vessels and piping
 - British Standards on pressure vessels and piping

Sample Questions From Past Year Papers for Practice of Professional Engineering Examination Part 2 (Mechanical)**Section 1 - Compulsory****Question 1**

(All **TEN** parts in Q1 carry equal marks)

- 1.1 (a) When is pressurization required for staircases? What are the performance criteria that must be achieved in pressurization?
- (b) For duct penetrations, when are fire dampers not permitted?
- (c) Describe how you should design a mechanical ventilation system for a smoke free lobby.
- 1.2 (a) Where passenger lifts are installed in a building with manual or automatic fire alarm system as required in the code, describe how the lifts should function when the fire alarm is activated.
- (b) Also describe how the lifts should function in the event of normal power failure or interruption.
- (c) In a building without standby generator what should you provide for the safe operation of the passenger lifts in the event of main power failure or interruption?
- 1.3 Town gas is to be provided for food and beverage outlets in a new commercial building development.
- (a) What are the requirements if the gas piping is to be routed through a naturally ventilated basement car park?
- (b) Describe the interlocking system to be provided if the kitchen of a food and beverage outlet is not naturally ventilated and is located in the basement.
- (c) What are the requirements if the gas piping is routed within the false ceiling of an air conditioned corridor which is 30 m long at storey 1?
- 1.4 (a) What is hot-tapping as practiced in process plant operation?
- (b) Under what considerations can hot tapping technique be used?

-
- 1.5 Discuss the purpose of pressure testing? Write short notes on the following pressure testing methods:
- (a) Leak testing;
 - (b) Pneumatic testing; and
 - (c) Proof testing.
- 1.6 (a) Explain the meaning of “design point” in the design of an Ordinary Hazard sprinkler system.
- (b) A circular duct is located more than 150 mm from the wall. What is the maximum width this can be before a sprinkler must be installed underneath it?
- (c) What is the maximum distance below a non-combustible ceiling that a sprinkler may be installed?
- 1.7 (a) State the density of discharge (mm/min) for OHII design.
- (b) Explain briefly the operation of a pre-action sprinkler system.
- 1.8 In air-conditioning cooling load calculations for the purpose of sizing systems, what are the indoor and outdoor design conditions to be used? Support your answers with recommendations from the relevant code of practice.
- 1.9 In designing an air-conditioning system to handle out-gassing from furnishings and other works what provisions must be made to the system?
- 1.10 (a) What is the definition of “Factor of Safety” as associated with the use of steel wire ropes for hoisting?
- (b) What are the respective minimum Factor of Safety for stationary and running wire ropes used for winches and cranes?

(28 marks)

Section 2 – Answer 4 Out 7 Questions**Question 2**

- (a) What are the primary objectives in maintaining swimming pool water in a safe and pleasant condition?
- (b) Calculate the minimum volume of a storage sump (m^3) and the pump flow rate in l/s for a pumped drainage system with a catchment area of $800m^2$. You may use the data in Table 1 below.

Table 1

Duration (hrs)	3	4	5	6	12	24
Total Rainfall (mm)	151.4	210.6	253.4	281.9	376.7	533.2

(18 marks)

Question 4

- (a) What are the differences between a winch and a hoist?
- (b) Under what conditions can you use a winch for lifting?
- (c) You have to pull a load of 6,000kg. The load is not and cannot be mounted on wheels. The only winch you have at hand is one rated at 5,000kg. Suggest a method that you may use to effect the pull.

(18 marks)

Question 6

Use the isometric design of an Ordinary Hazard Group II sprinkler system as shown in Figure 3, to design according to the pre-calculated method.

- (a) Determine the water supply requirements and show them on Figure 3.
- (b) Size all range points.
- (c) Insert the Design Point.
- (d) Size all distribution pipes downstream of the Design Point.
- (e) Complete the Statement of Distribution Pipe Losses.

Submit the answer sheets provided with the rest of your answers in the answer book.

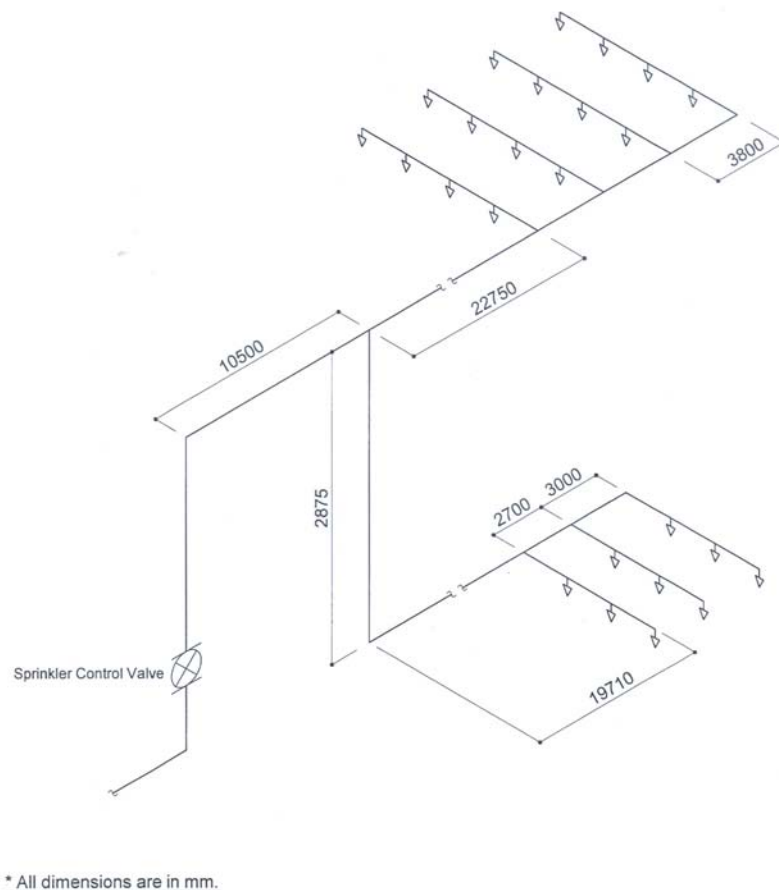

Figure 3. Isometric design of an Ordinary Hazard Group II sprinkler system
(18 marks)

Question 8

A pressure vessel consisting of a shell and two hemispherical heads is constructed from SA 516-70 carbon steel material (Tensile Strength – 70 ksi). The self-reinforced nozzles in the vessel are made from type SA 213-316 stainless steel material (Tensile Strength – 75 ksi). The vessel is shut down eight times a year for maintenance. At start-up, the full pressure of 300 psi and full temperature of 450°F are reached in two hours. The maximum ΔT between any two points during start-up is 300°F. At normal operation, the ΔT is negligible. At shutdown, the maximum ΔT is 100°F. Determine the maximum number of years that this vessel can be operated if a fatigue evaluation is not performed.

You may use the following information:

- (i) In accordance with ASME Boiler and Pressure Vessel Code, Section VIII Division 1, paragraph UG-22 or U-2(g), fatigue analysis is not required for materials with a tensile strength of less than 80 ksi when the total number of cycles in (a) through (d) below is less than 1000.
- (a) The design number of full range pressure cycles including startup and shutdown.
- (b) The number of pressure cycles in which the pressure fluctuation exceeds 20% of the design pressure.
- (c) Number of changes in metal temperature between two adjacent points. These changes are multiplied by a factor obtained from Table 2 in order to transform them to equivalent cycle number.

Table 2

Metal Temperature Differential, °F	Factor
50 or less	0
51 to 100	1
101 to 150	2
151 to 250	4
251 to 350	8
351 to 450	12
Higher than 450	20

- (d) Number of temperature cycles in components that have two different materials where a difference in the value $(\alpha_1 - \alpha_2) \times \Delta T$ exceeds 0.00034. Where, α is the coefficient of thermal expansion and ΔT is the difference in temperature.
- (ii) The coefficient of expansion for carbon steel is 6.5×10^{-6} in./in./°F and that for stainless steel is 9.5×10^{-6} in./in./°F.

(18 marks)
